

---

## MX 203-6-41-q

Manually Loaded Wafer Geometry  
Gauge for Solar Wafers

### **Application**

Control of Thickness and Shape of  
Solar Wafers

## 1 Description



The MX 203-6-41-q is a manually loaded wafer geometry measuring instrument for silicon solar wafers of 156x156mm<sup>2</sup> and below. This equipment is dedicated to control the thickness and shape of wafers.

Like on all other E+H wafer geometry instruments, E+H's technology of contactless capacitive distance sensors is applied.

The pure measurement time is max. 8 sec per wafer. A complete wafer cycle with manual loading and unloading by an operator takes approx. 20 sec.

## 2 The Wafer Geometry Station

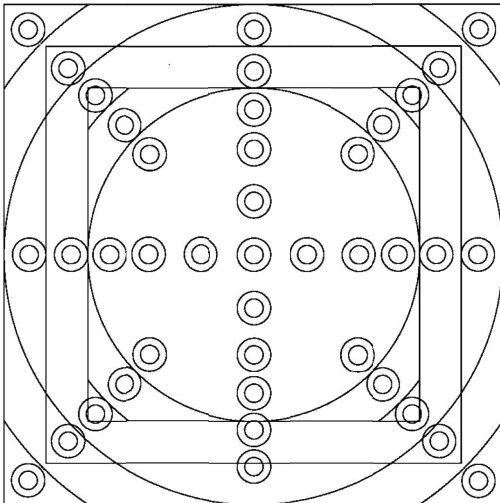

The wafer geometry station consists of a lower and an upper probe head. Every probe head is based on a flat plate into which 41 capacitive distance sensors are embedded in a radial pattern. Both sensor plates are mounted horizontally and face-to-face to each other.

The distances between each pair of sensors are gained by a simple calibration with a reference wafer.

### 3 Handling of Wafers



The wafer is put onto the tray and the drawer is closed manually by the operator. During this movement the wafer is inserted into the air gap between the two probe heads.

The operator turns the knob in front of the drawer and the wafer is laid down onto resting points mounted on the lower probe head. Thereafter the measurement starts. After finishing the measurement the operator has to turn back the knob and to pull out the tray.

The tool can be supplied with a variety of centering-frames to be able to insert different wafer sizes. These centering-frames are put onto the tray and allow the operator to align the wafer correctly while inserting it.

### 4 Measurement Principle

The thickness and warp measurement is performed within one cycle.

During measurement the wafer rests freely onto resting points which are mounted inside lower probe head.

The distances of the top sensors to the wafers frontside and the distances from the bottom sensors to the backside of the wafer are measured.

The thickness is derived by subtracting the sum of the measured distances (top+bottom) from the known distance between each pair of sensors. The warp measurement uses in addition the distances from the bottom.

The wafer rests in a still position during the whole measurement. This leads to highly repeatable and precise measurements.

## 5 Technical Specifications

### Mechanics

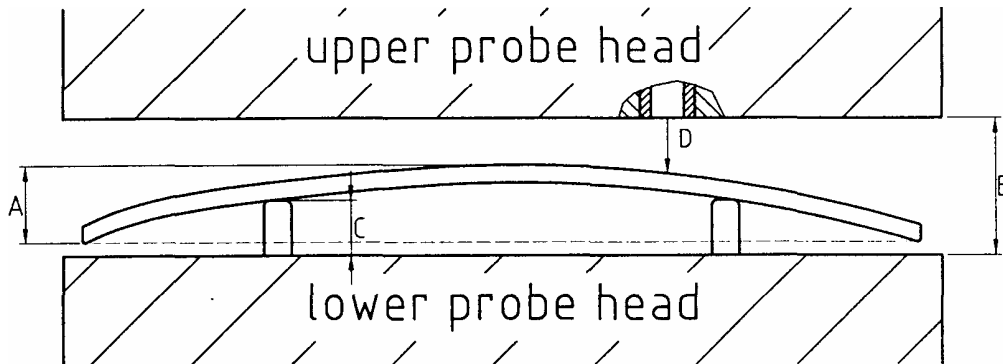

Total Distance ('B')	2000 $\mu\text{m}$
Resting points amount	21
Resting Point Height ('C')	600 $\mu\text{m}$
max. Distance ('D')	1500 $\mu\text{m}$

Please note that these limitations can be changed upon request.

### Measurement Range by wafer size

<b>Wafer Sizes (square / pseudo square)</b>	<b>100x100*</b>	<b>125x125*</b>	<b>156x156</b>
Measuring Points	21	33	41
<b>Wafer Sizes (round)</b>	<b>100mm*</b>	<b>125mm*</b>	<b>150 mm*</b>
Measuring Points	17	25	33
Warp Range	80 $\mu\text{m}$	160 $\mu\text{m}$	200 $\mu\text{m}$
Thickness Range			160 – 700 $\mu\text{m}$
Thickness & Warp ('A')			max. 900 $\mu\text{m}$

\* One centering-frame included. More centering-frames optionally available.

## Sensor Characteristics

Measuring Range of One Sensor	1520 $\mu\text{m}$
Resolution	14 bits

## Gauge Accuracy (at calibration temperature)

Absolute Thickness Accuracy	$\pm 0.5 \mu\text{m}$ (= center thickness)
TTV	$\pm (0.3 \mu\text{m} + 2\%$ of reading)
Precision	$0.15 \mu\text{m} + 1\%$ of TTV ( $1\sigma$ )
(measuring one wafer ten times)	
Bow-bf / Warp Accuracy	$\pm (3 \mu\text{m} + 5\%$ of reading)
Bow-bf / Warp Precision	$1 \mu\text{m} + 1\%$ of reading ( $1\sigma$ )
Warp = Sori according JEIDA, (Warp and Bow not gravity-corrected)	

### Measurement Time

(close drawer, measurement, open drawer)	max. 10 sec. / wafer
--	----------------------

### Dimensions

	Width 360 mm
	Height 190 mm
	Depth 360 mm
Weight	25 kg
Mains	110 - 240 V selectable, 50/60 Hz

Power Consumption	20 W
-------------------	------